

Springfield Arbor

Assembly & Mounting Instructions

General Information:

- Read instructions through carefully before beginning assembly.
- Identify each component from material list.
- When assembling components, place on a non-abrasive surface to avoid scratches.
- Do not use excessive force when assembling components.
- In the event of missing or defective parts, please call our customer service department at 1-800-282-9346 (ext.#20).

Materials Included: (In 2 boxes)

Part #	Description	Quantity
1	Arches (2 lefts, 2 rights)	4
2	Keystones	2
3	7/8" x 1 1/2" x 24 1/4" Spindles	6
4	3 1/2" sq. x 66" Posts	4
5	7/8" x 1 1/2" x 25 3/4" Rails	4
6	29 1/2" x 48" Diamond lattice	2
7	Hardware kit (Includes): 3/4" Self-tapping stainless screws	28

Tools Required:

- Cordless drill with #2 Robertson bit
- Tape measure
- Level
- Shovel

Materials (Optional): (Not Included)

- Four 2" x 4" x 24" treated wood posts.
- Two bags of pre-mix concrete. *

* Strongly recommended for installation in high wind or high traffic areas.



(Fig. 2)

Post layout for installation.

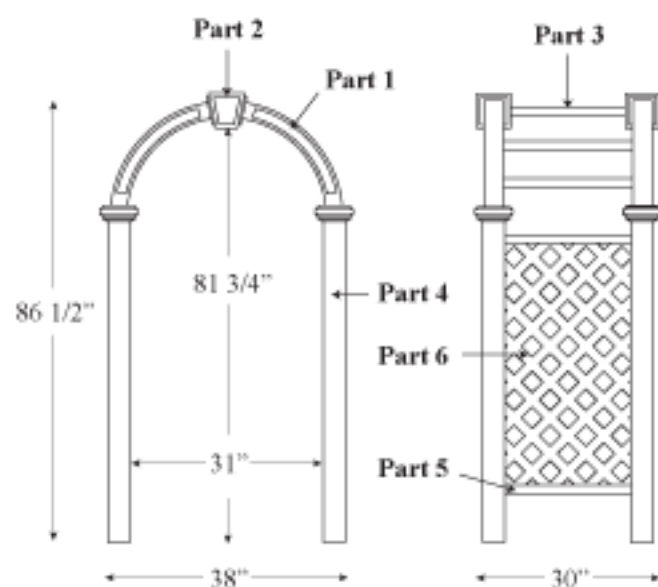

(Fig. 1)

Product dimensions & Part identification.

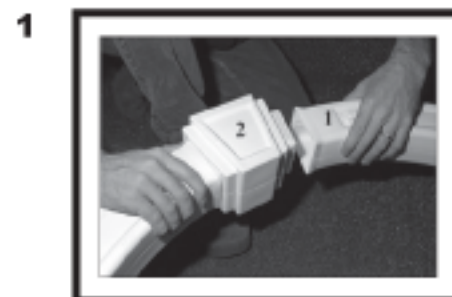

Making sure the spindle sockets are facing the same side, snap the left and right arch (part 1) onto the keystone (part 2). The left and right sides can be identified by a small L or R located at the solid end of each arch.

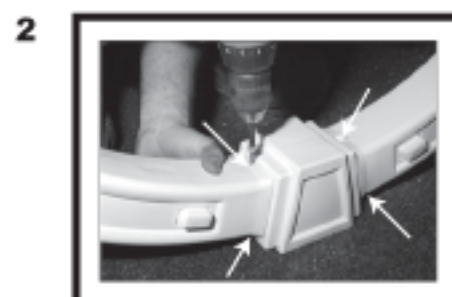

Using four screws, fasten the arches to the keystone on both sides as illustrated (arrows show each screw location). **Note:** all screws are self-tapping and require no pre-drilling. Repeat steps 1 and 2 for the remaining keystone and arches.



Place two spindles (part 3) over the sockets on either side of the keystone. Using one screw for each end, fasten the spindles to the arch as illustrated. Make sure the screw is positioned close to the arch wall to ensure proper attachment to the socket.

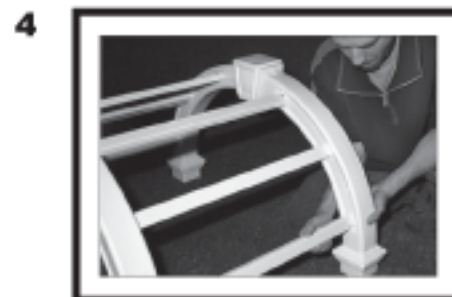

Place the remaining spindles onto the sockets. Fasten both ends of each spindle as shown in step 3. Set aside the completed arch assembly.



Slip the rails (part 5) onto each end of the lattice (part 6) and slide them down the full width of the lattice.

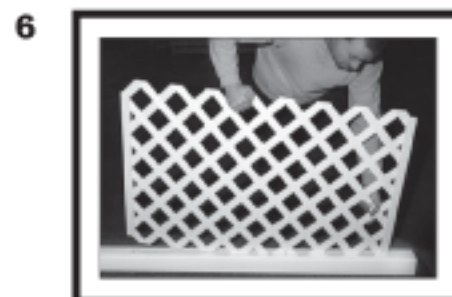

Lay out one of the posts (part 4). Start at one end and push the lattice into the slot in the post. Insert the rail ends into the holes, making sure they are pushed in past the locking tabs.

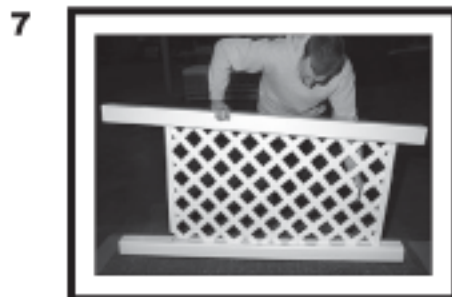

7 Flip the panel over onto one of the other posts and repeat step 6. Repeat steps 5 through 7 for the opposite side panel.



8 With assistance, stand the side panels up and place the completed arch assembly into the open ends of each post. **Note:** the top of the side panel is determined by the rail which is closest to the end of the post.



9 Using two screws per post, fasten the arch assembly to the side panels as illustrated (arrows show screw locations). Position the screws directly under the arch cap to ensure proper attachment to the arch.



10 Place your arbor in the desired location. Measure the distances between the posts as shown in (Fig.2) on the front cover. Mark these locations on the ground.



11 Lay the arbor down and insert a two foot long 2x4 (not included) into the open end of each post on a 45 degree angle. Push the wood in until it hits the bottom rail. This will leave approx. 12" for ground mounting. **Note:** If you have an alternative ground or surface mounting system, disregard steps 11 through 13.



12 Use two screws per post (not included) and fasten the 2x4's to the vinyl post as illustrated.

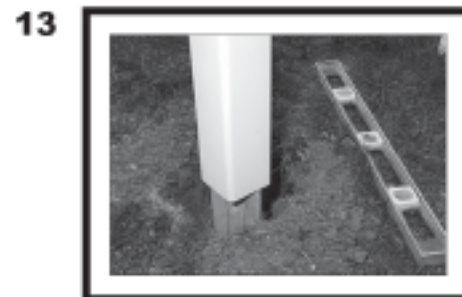

13 Dig four 12" deep holes in the marked post locations. With assistance, set the arbor into position and verify the spacing between the posts.



14 Place a level on top of the rails to check each side for plumb. At this time, you may need to adjust the depths of the holes. **Note:** the wood inserts should be completely buried, leaving the vinyl posts at ground level.



15 Use the level to check each post. Once you are satisfied with the orientation, fill in the holes. For added stability in high wind or high traffic areas, we recommend using pre-mix concrete (not included).

Questions ? :

If you have any questions concerning the assembly or installation of this product and require assistance, please call our **Customer service department at 1-800-282-9346 (ext.#20)**, Weekdays from 8:00 am. to 4:00 pm. Eastern standard time.

If you have any comments or suggestions about our product or service, please let us know! Call: **1-800-282-9346 (ext.#24)**, or E-mail: **info@newenglandarbors.com**

To learn more about us, visit us on the web at: **www.newenglandarbors.com**