

# GAMBREL DORMER

#16584

11/15/2004

LDR CH

An attractive alternative to skylights, with modern function and country appeal

Manufactured by Marco Wood Products

1. Assemble framing brackets, using pieces LY and LZ as shown. Fasten using two 3" screws per bracket.

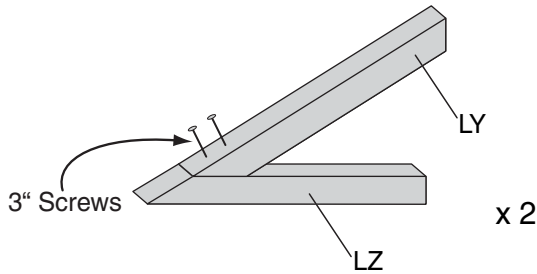

2. Using wall sub panel A, attach brackets as shown. Make sure sub panels are flush to the front and bottom of the brackets. Attach using one 1-1/4" screws and two 2" nails per bracket.

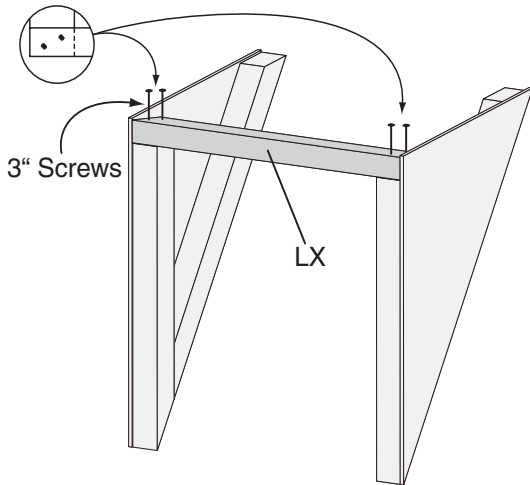
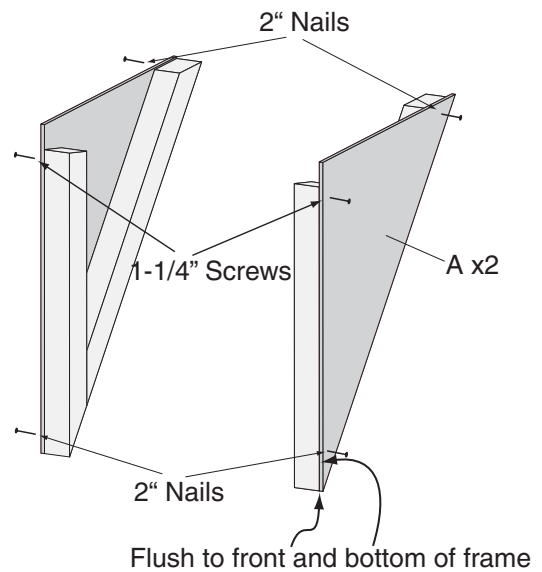

3. Attach the window header, LX, to the top of the brackets as shown. Fasten using four 3" screws.

4. Attach waferboard spacers to the framing. Begin with the top horizontal piece, C, flush to the top of the roof cleat. Next attach the two vertical pieces, B, flush to the outside. Finally attach the bottom horizontal piece, C. Fasten all pieces using eight 1-1/4" screws.

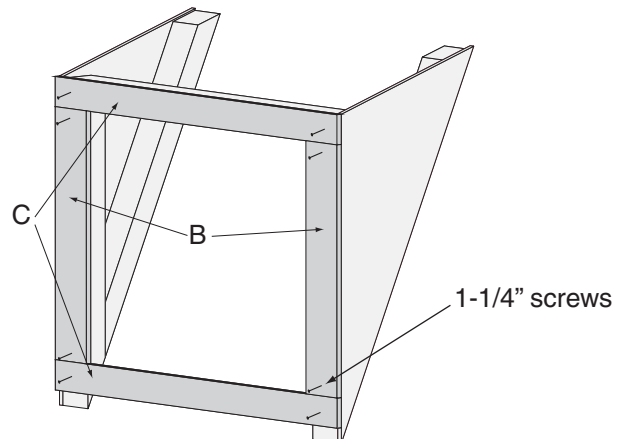

Part I.D.	Qty.	Description	Size
A	2	Wall Sub Panel	3/8" x 9" x 27-7/8"
B	2	Vertical Filler Strips	3/8" x 2-7/8" x 16-3/4"
C	2	Horizontal Filler Strips	3/8" x 2" x 28-3/16"
D	1	Roof Panel	3/8" x 14" x 30"
E	1R/1L	Wall Panel	3/8" x 8-3/4" x 27-1/16"
F	12	Flashing Cards	5" x 8"
G	1	Flashing Card	4" x 32"
FA	2	Horizontal Window Trim	1" x 4" x 16-1/4"
FB	2	Vertical Window Trim	1" x 3" x 29"
LX	1	Window Header	2" x 3" x 27-1/2"
LY	2	Roof Cleat	2" x 3" x 24-1/8"
LZ	2	Window Side Framing	2" x 3" x 20-1/8"
	1	Window	
	1	Hardware Kit	

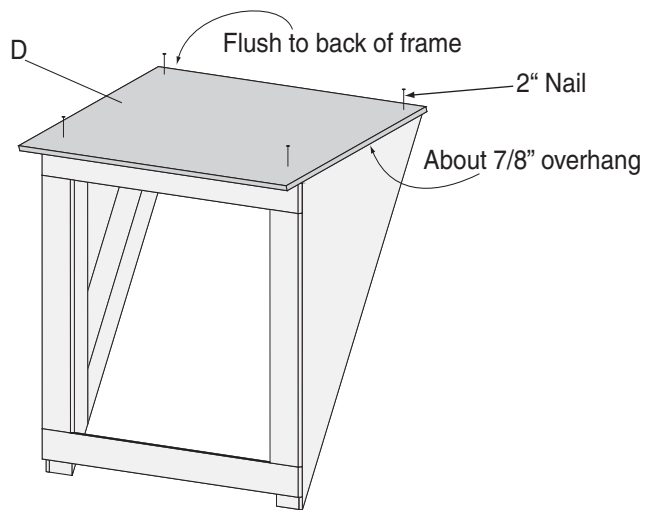

5. Attach the roof panel, D, using four 2" nails. The roof panel should be flush to the back and centered.

6. To cut opening for dormer, locate the rafters on the roof. Cut a hole 22-1/2" wide by 28-1/2" high.

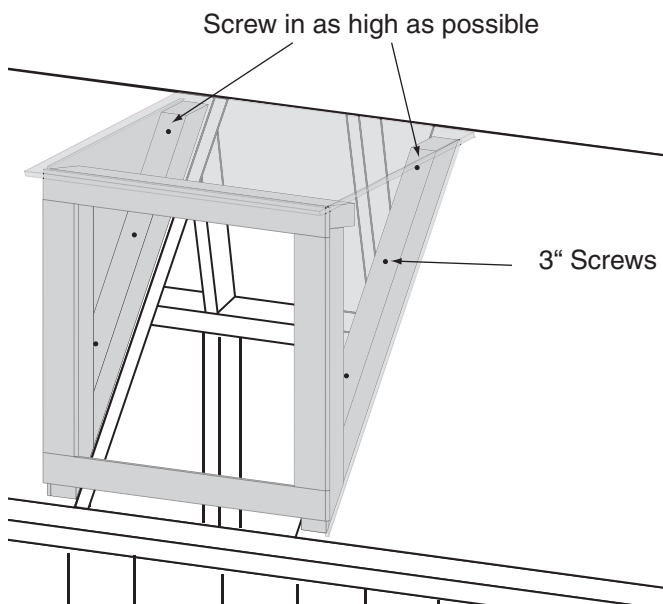
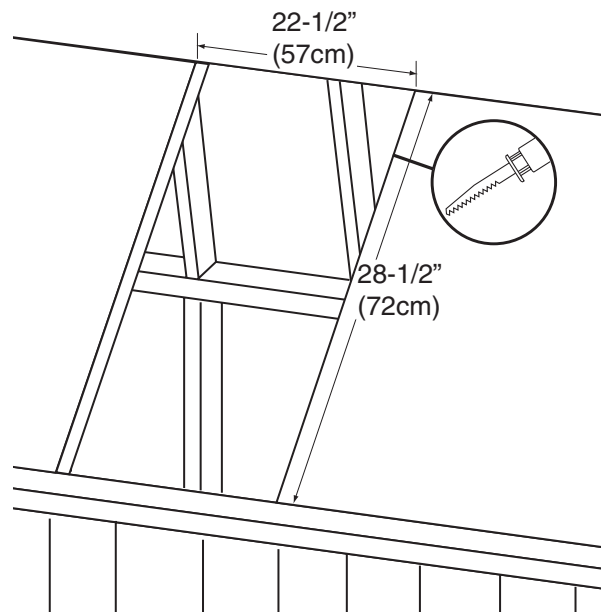

7. Center dormer over hole and attach using six 3" screws in the locations shown. Screws should be driven at a slight angle to be driven into the rafters.

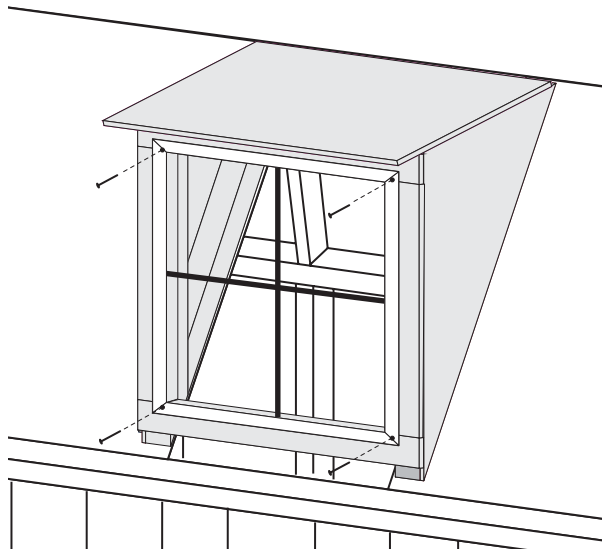

8. To attach window, center in the hole and fasten using four 1-1/4" screws in the pre-drilled corner holes.

9. Using the square edge of a table or bench, bend the twelve step flashing cards, F, to a 90 degree angle down the center. Beginning at the bottom edge of the dormer fasten the first card using roofing nails(not supplied) in the bottom corners only. The next piece should over lay the first piece and should leave a 5" reveal, attach both pieces using nails in the bottom corners only. Continue process all the way up each side of the dormer. Top pieces will need to be cut flush to the top of dormer using regular tin snips and fastened in all four corners.

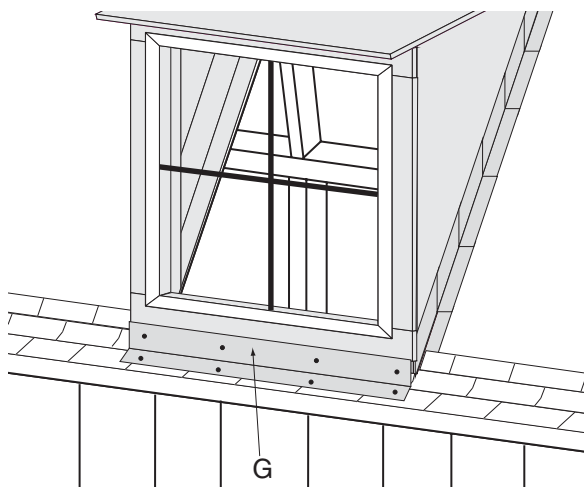
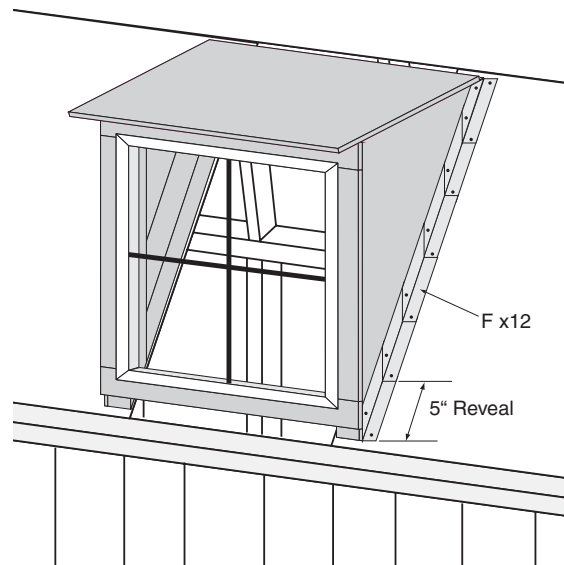

10. Shingle the building one complete row up past the bottom edge of the dormer.

11. Using the square edge of a table or bench bend the front flashing, G, to slight angle (about 30 degrees) down the center. Place against dormer and adjust angle if needed. Fasten to the dormer and roof using roofing nails as shown.

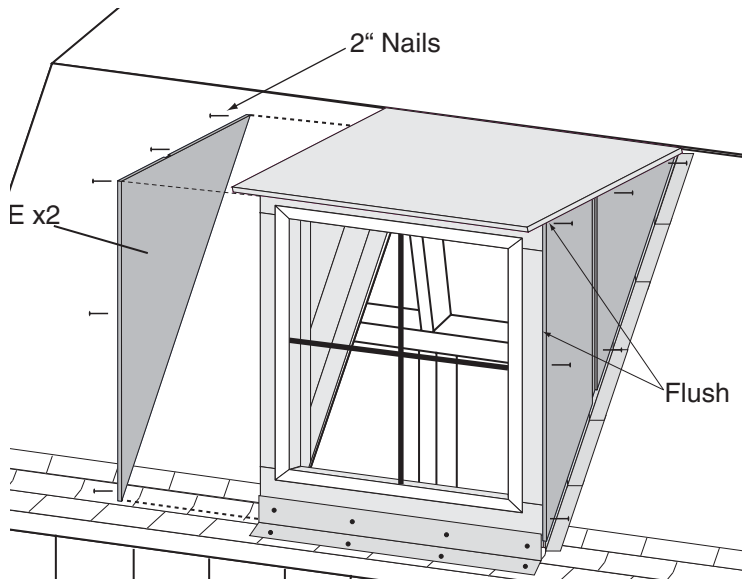

12. Attach the siding, E, as shown. Make sure the siding is flush to the front of the dormer and flush to the underside of the roof panel. Attach siding using six 2" nails per piece. Siding should leave about 3/8" gap above roof to allow for shingles.

13. Attach front trim using twelve 1-1/4" screws, beginning with the top horizontal piece, FA. Make sure the trim is flush to the underside of the roof panel and centered on the dormer. Attach the vertical trim pieces, FB, flush to the outside of the dormer. Finally, attach the bottom trim piece, FA.

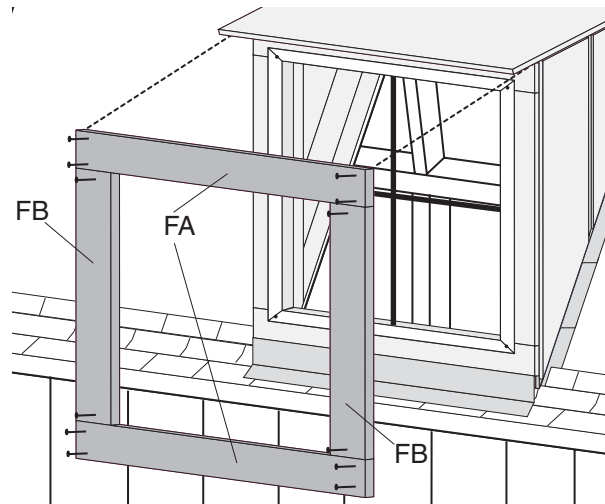

14. To shingle dormer, begin at the front of the roof panel and work backwards toward the roof pitch. Exposure should be 5", the same as the roof. Run the shingles all the way up until the dormer is covered. Shingle the remainder of the building.

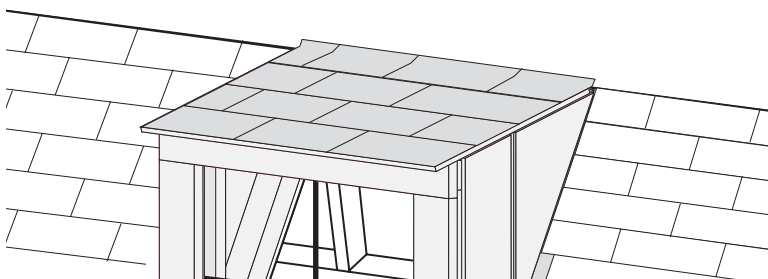

15. Using an exterior grade caulk, be sure to caulk all joints around the dormer including above and below trim and along the underside of the roof panel. Paint must also be applied to trim and siding.