

CUPOLA

#16612

11/02/04

Manufactured by Marco Wood Products

Made in the U.S.A
Toll-Free 1-800-437-0784

Handy Checklist & Assembly Instructions

— BEFORE YOU BEGIN —

■ First...

Read these instructions thoroughly before you begin assembly. Assembly is easiest if you follow the steps in the order shown.

In a drawing, a dotted line represents a part hidden from view (like a part under a panel).

Lumber is graded from only one side. Check the part for the most attractive face and make sure to face it to the outside.

■ Check all parts

Compare the parts you have to the list on this page. If a part is missing, circle the part in question and call us toll-free at 1-800-437-0784.

■ Squareness is Very Important!

Keeping all 90° corners and 90°perpendiculars square throughout the assembly of this kit will make each succeeding step easier and is necessary to assure that all components fit together properly.

■ Always wear OSHA-approved safety glasses throughout the assembly process

■ Tools Required

- Hammer
- Key Hole Saw
- Phillips Screwdriver
- Step ladder
- Pencil
- Tape measure

■ Optional Tools

- Electric Drill with #2 Phillips Tip
- Sabre Saw
- Square
- Nail Pouch

I.D.	Use/Description	Size (in)	Size (cm)	Qty
Parts List				
<input type="checkbox"/>	(A)SIDE PANELS....	3/8 x 11-3/4" x 19-1/8"	30.5 x 48.6 cm 2
<input type="checkbox"/>	(D)SIDE PANELS(to be cut)...	3/8 x 11-3/4" x 20"	30.5 x 50 cm 2
<input type="checkbox"/>	(AC)INTERIOR CORNER SUP.	1-1/2" x 2-1/2" x 10"	.26 cm 4
<input type="checkbox"/>	(BB)CORNER TRIM	3/4"x 1-1/2" x 10-1/2"	.27 cm 8
<input type="checkbox"/>	(BP)TOP TRIM	3/4"x 1-1/2" x 20-3/4"	.52 cm 4
<input type="checkbox"/>	(--)LONG ROOF SUPPORT...	3/4 x 5-1/4" x 23-3/4"	14 x 61 cm 1
<input type="checkbox"/>	(--)SHORT ROOF SUPPORTS...	3/4 x 5" x 11-5/8"	13 x 30 cm 2
<input type="checkbox"/>	(--)ROOF PANELS...	3/8 x 12" x 21-1/2"	30.5 x 55 cm 4
<input type="checkbox"/>	(--)HARDWARE KIT 1
(INCLUDES 1-1/2" & 2" FINISH NAILS, 3" SCREWS, 1" SCREWS)				
<input type="checkbox"/>	(--)CUTTING TEMPLATE 1

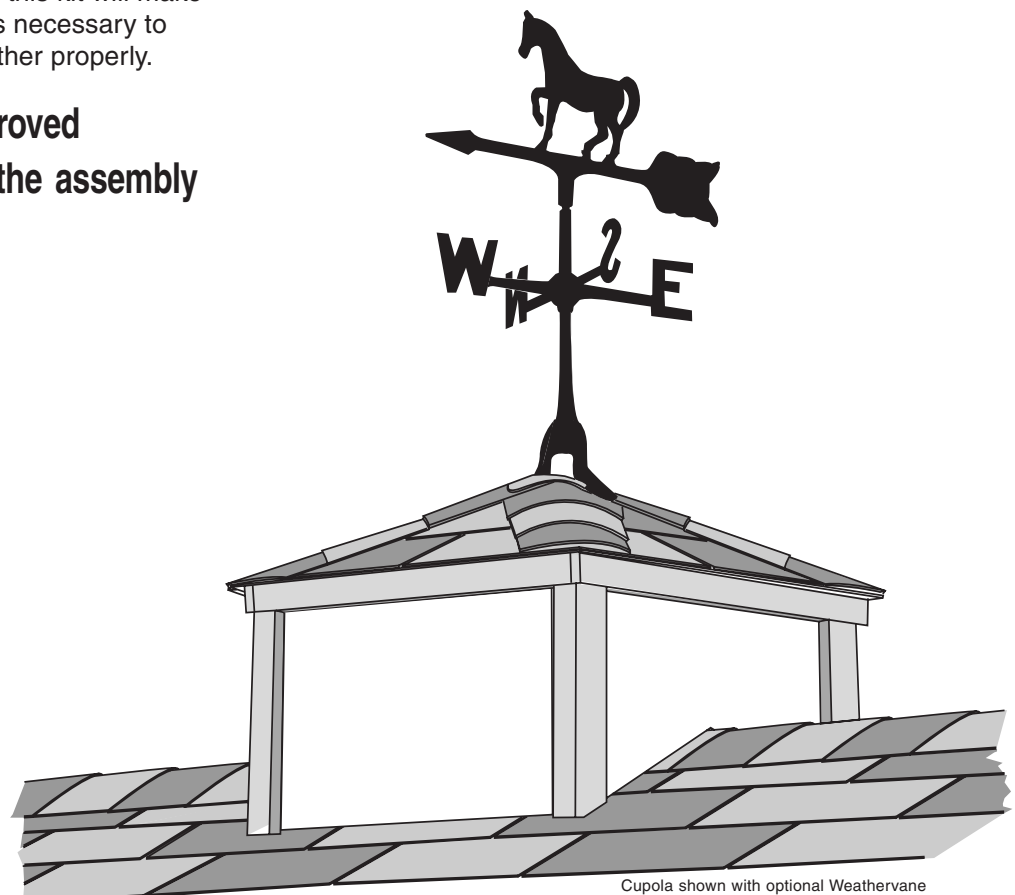

Cupola shown with optional Weathervane

A. Position Side Panel 11-3/4" x 19-1/8" **(A)** on top of two Interior Corner Supports 1-1/2" x 2-1/2" x 10" **(AC)** with supports flush to sides and top of Panel and Panel siding facing up. Secure with six 1-1/2" finish nails **(C)** through Panel into supports.

Repeat other Side Panel 11-3/4" x 19-1/8" **(A)** and two Interior Corner Supports 1-1/2" x 2-1/2" x 10" **(AC)**.

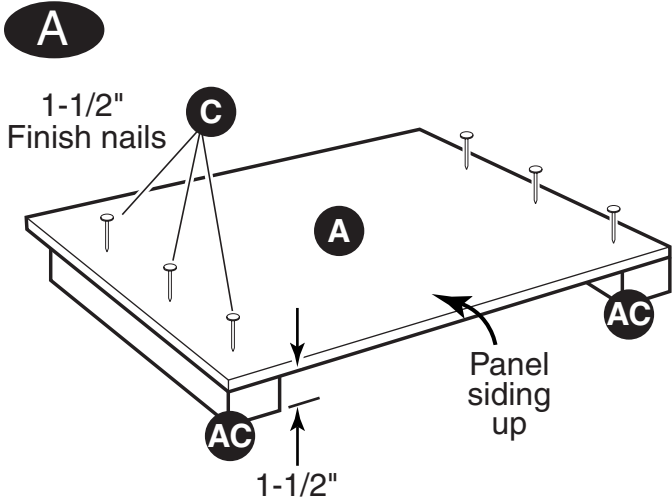

B. Position Side Panel 11-3/4" x 20" **(D)** on top of Corner Trim 3/4" x 1-1/2" x 10-1/2" **(BB)** with Corner Trim flush to sides and bottom of Panel. Secure with two 1" screws **(C)** through Panel into Corner Trim.

Repeat other Side Panel 11-3/4" x 20" **(D)** and two Corner Trim 3/4" x 1-1/2" x 10-1/2" **(BB)**.

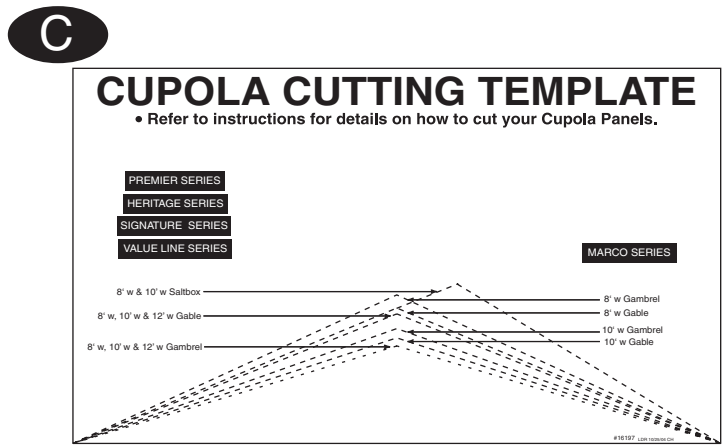
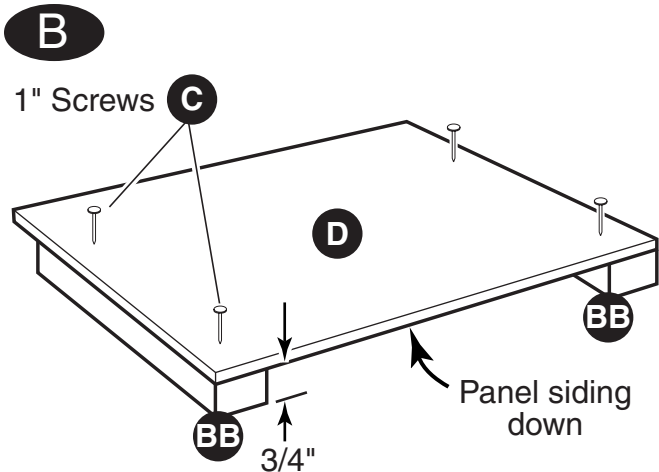

C. Locate the cardboard cutting Template shown in Step C, you will need it for the next step. Find your building on the template and cut the template to the building pitch. Check the angle of the template by placing it on the roof.

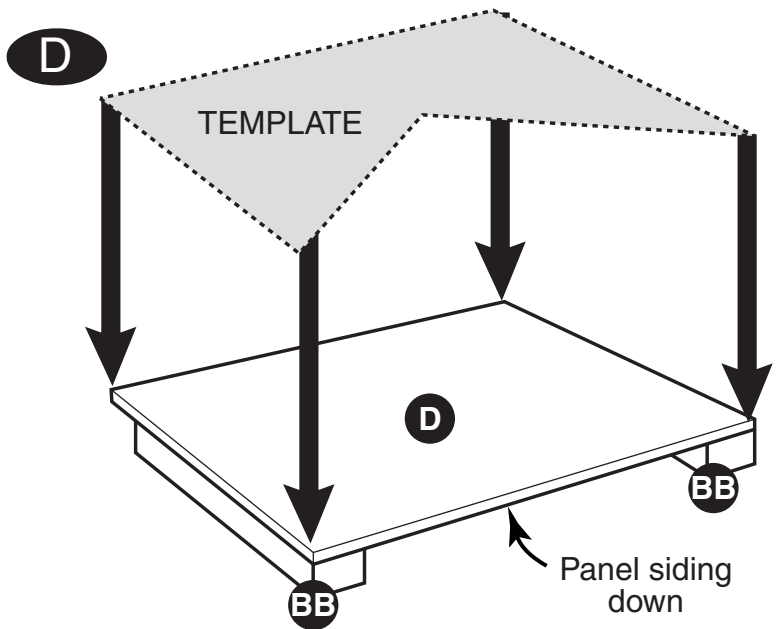

D. Using the Template, cut out the profile that matches your building. See Template for building chart. **IMPORTANT:** Make sure you only cut the 11-3/4" x 20" Panels **(D)** with the Corner Trim **(BB)** pieces attached.

E. Mark Template and cut out with a Key Hole Saw or a Sabre Saw as shown in step E. Be sure Corner Trim (**BB**) is flush to bottom of Panel where it is to be cut. Cut out other 11-3/4" x 20" Panel with Corner Trim (**BB**) attached in the same manner.

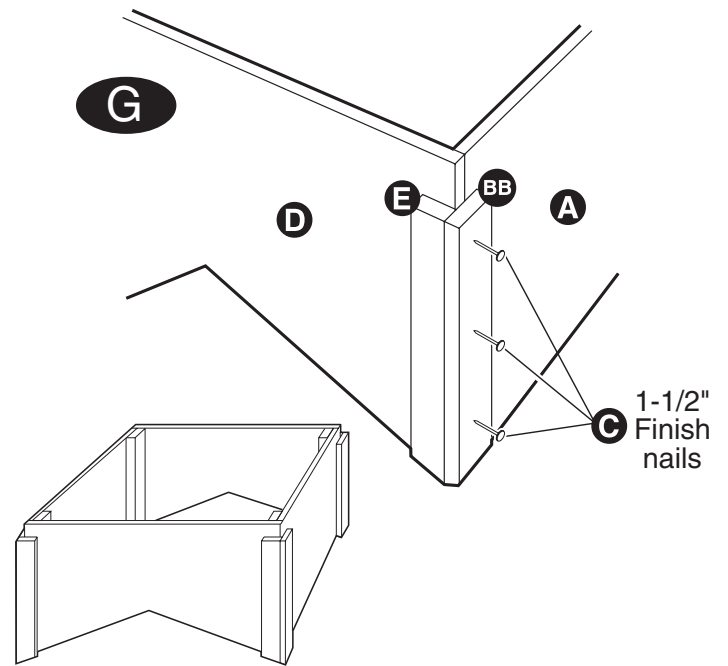
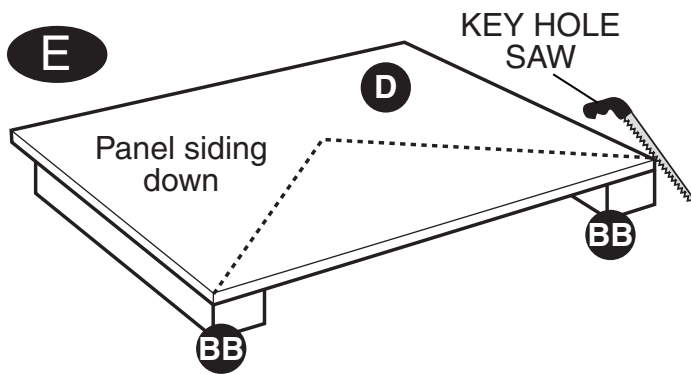

G. Position un-cut Corner Trim 3/4" x 1-1/2" x 10-1/2" (**BB**) over corner of Panels flush to front of Corner Trim (**E**). Secure with three 1-1/2" Finish nails (**C**) through Corner Trim into Panels and Interior Corner Supports.

Install other three un-cut Corner Trim (**BB**) pieces in the same fashion at corners.

F. Stand up the two Side Panels (**A**) and position cut Panel (**D**) on top of Side Panels and Corner Supports flush to outside edges of Side Panels. Secure with six 2" finish nails (**C**) through Front Panel into Interior Corner Supports (**AC**).

Turn assembly over and install second cut Panel (**D**) in same fashion.

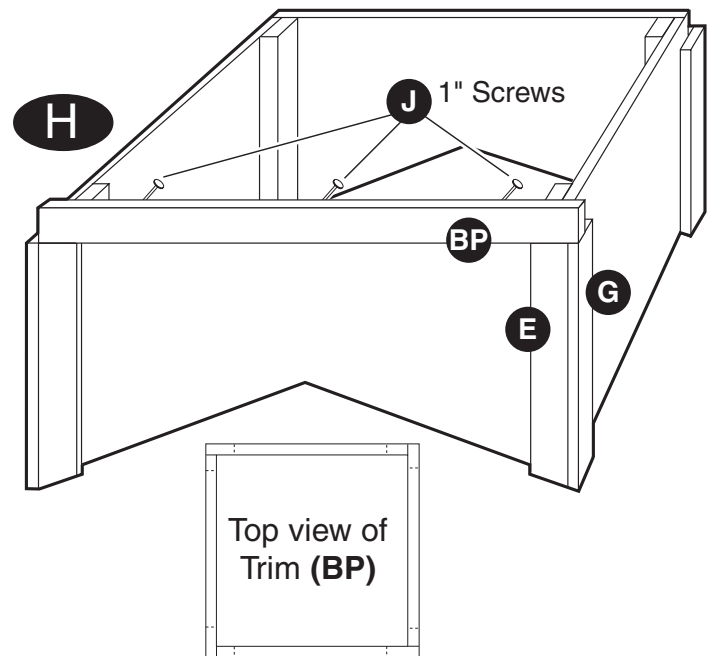
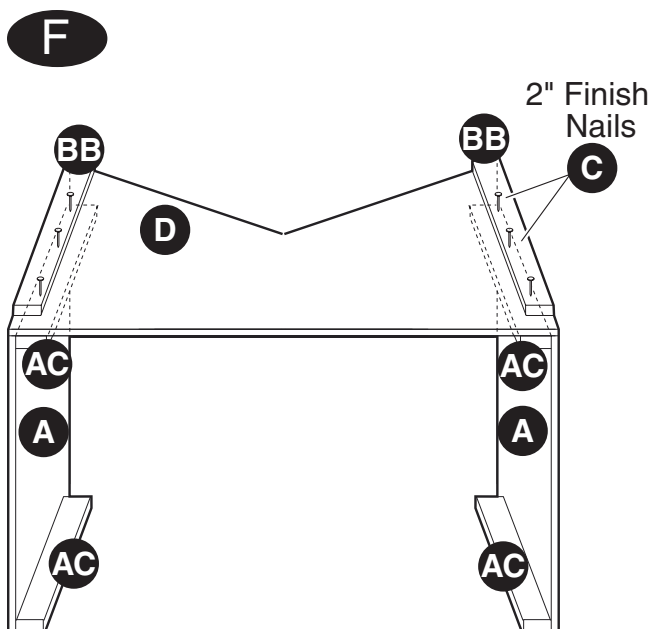

H. Position Top Trim 3/4" x 1-1/2" x 20-3/4" (**BP**) on top of Corner Trim (**E**) and (**G**) as shown. From inside Cupola, secure with three 1" screws (**J**) through Panel into Top Trim (**BP**).

Note: Top Trim (**BP**) will stick up about 1/4" above Side Panels.

Install other three Top Trim (**BP**) in sequence around Cupola in same fashion.

I. Position Long Roof Support $3/4" \times 5-1/4" \times 23-3/4"$ (**K**) and Short Roof Support $3/4" \times 5" \times 11-5/8"$ (**L**) as shown and connect with two $1-1/2"$ Finish nails (**C**).

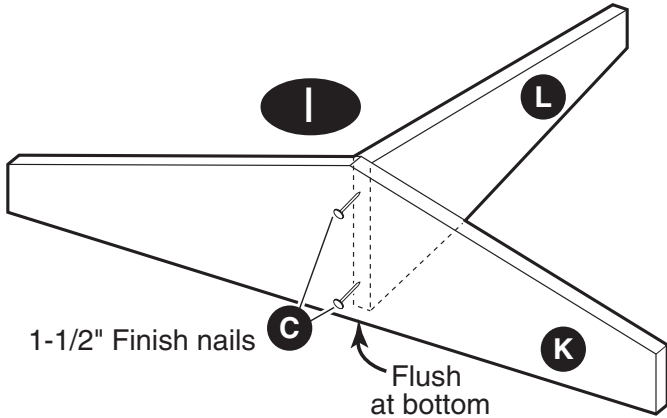

J. Position second Short Roof Support $3/4" \times 5" \times 11-5/8"$ (**L**) as shown and connect with two $1-1/2"$ Finish nails (**C**) toe-nailed top and bottom.

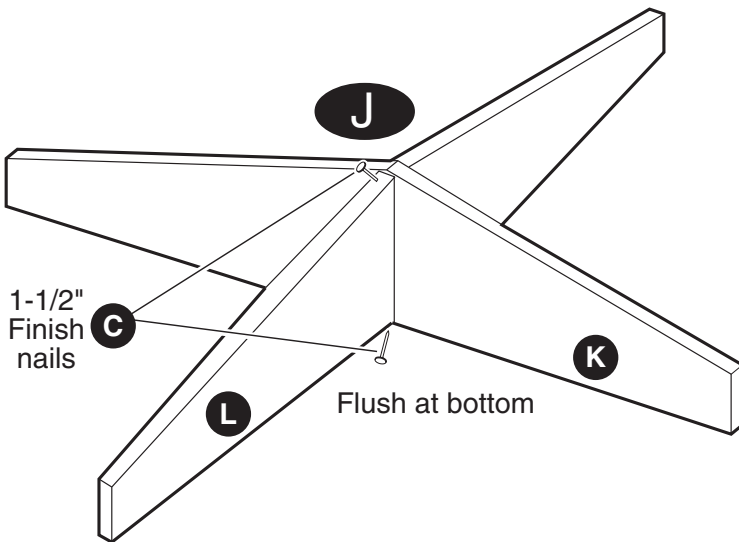

K. Position Roof Panel $12" \times 21-1/2"$ (**M**) centered on Roof Supports (**K**) and (**L**) and secure with six $1-1/2"$ Finish nails (**C**).

Install other three Roof Panels in sequence around Roof Supports in same fashion.

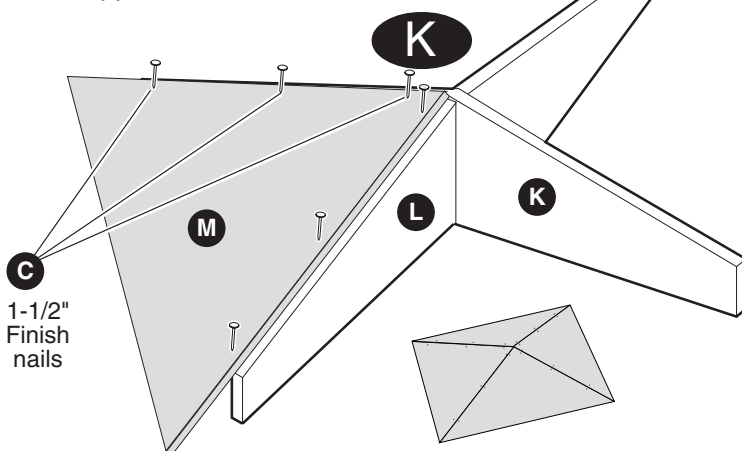

L. Position four assembled Roof Panels (**M**) on top of Top Trim (**BP**) and secure with twelve $1-1/2"$ Finish nails (**C**) through Panels into all four Top Trim pieces (**BP**).

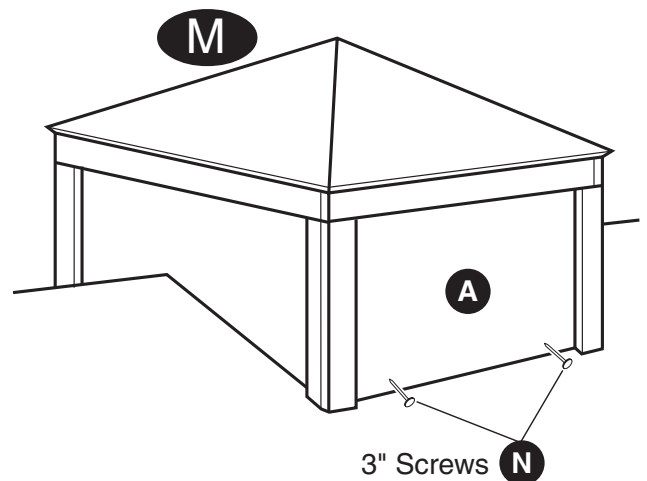
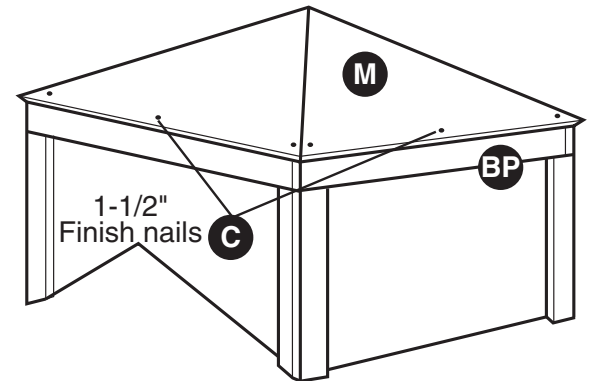
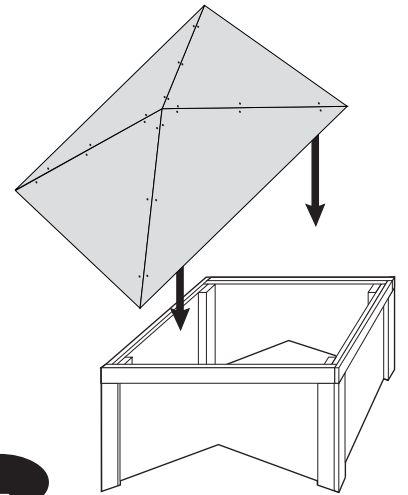

M. Position Cupola in desired location on roof peak and secure with four 3" screws (**N**) through Cupola Side Panels (**A**) into roof.

Caulk between all Cupola Panels and roof- and between all Cupola Corner Trim and Panels- and between trim and roof.

Finish painting and shingling per building instructions.