

# 10' REVERSE GABLE

## For 10' Wide Gable Buildings

Made in the U.S.A

Manufactured by Marco Wood Products

Part I.D.	Qty.	Description	Size
GPL	1	Gable End Panel Left	3/8" x 22-11/16" x 33-13/16"
GPR	1	Gable End Panel Right	3/8" x 22-11/16" x 33-13/16"
EGL	1	Gable Trim Left	4/4" x 2-1/2" x 38-11/16"
EGR	1	Gable Trim Right	4/4" x 2-1/2" x 38-11/16"
EEL	1	Horizontal Gable Trim Left	4/4" x 2-1/4" x 35-1/2"
EER	1	Horizontal Gable Trim Right	4/4" x 2-1/4" x 35-1/2"
UB	1	Ridgeboard	2" x 4" x 54-7/8"
EE	1	Gable Connector	1" x 3" x 17-7/8"
A	2	Large Roof Panel	7/16" x 25" x 23-7/8" x 42-3/4"
B	2	Small Roof Panel	7/16" x 25" x 33-11/16"

1

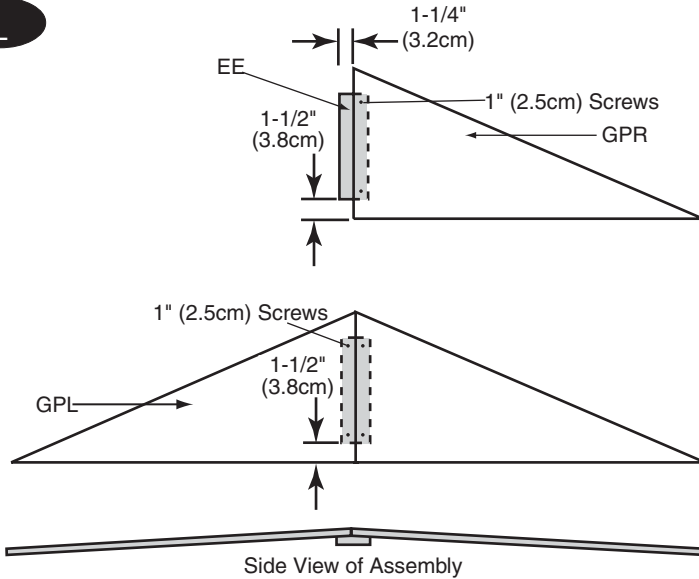

2

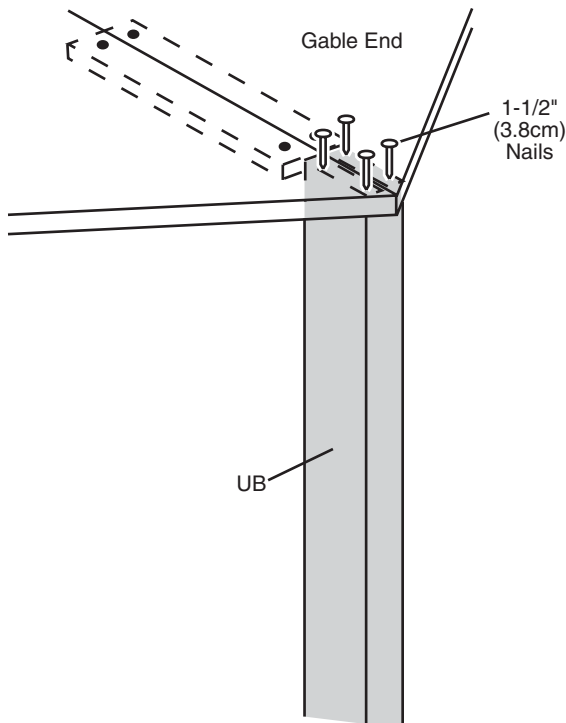

1. Place **EE** under one Gable end panel with Primer side up as shown keeping 1-1/4" in from edge and up 1-1/2" from bottom. Connect with two 1" screws through Panels into **EE**. Butt second Gable End up to first Gable End and attach in the same manner.
2. Position connected Gable Ends flush to top of Ridge Board **UB**. Connect with four 1-1/2" nails through Panels into Ridge Board.
3. Position all trim parts prime side down on flat surface as shown, keeping **EGL** and **EGR** Gable trim flush at peak and to Horizontal Gable trim **EEL** and **EER**. Center assembled Gable panels on top of trim as shown and secure with 1" screws through Gable panels into Trim as shown. Trim will overhang bottom as shown.

3

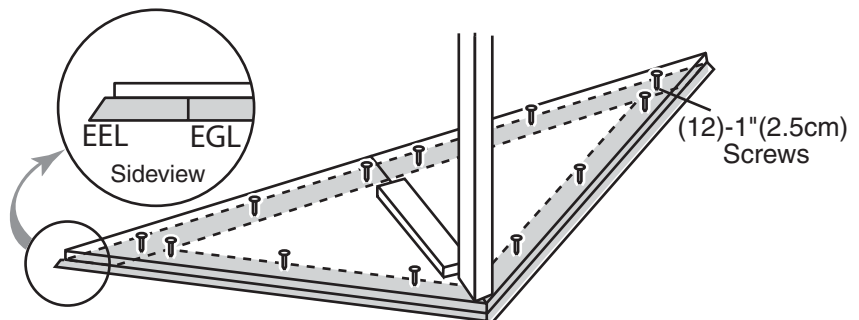
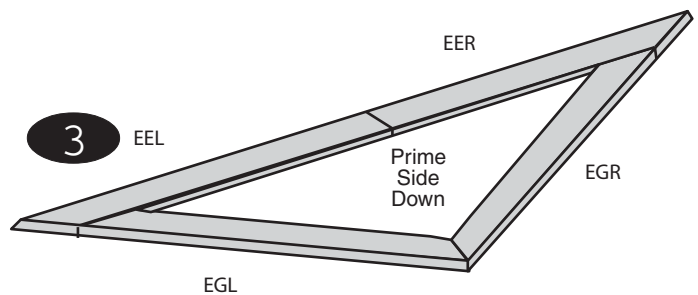

**UNDERSIDE VIEW**

4. Position Large Roof Panel flush at Peak and Front Trim. Secure with four 1-1/2" nails into Trim **EGL** and with two 1-1/2" nails into the Ridge Board **UB** use nail pattern as shown.

5. Position second Large Roof Panel flush to first Panel and Trim. Secure with four 1-1/2" nails into Trim **EGR** and with two 1-1/2" nails into Ridge Board **UB** use nail pattern as shown.

6. Position Gable Assembly on building Roof (usually centered over Door opening). **Note: Starter row of shingles should be applied first.** Secure Gable Assembly to Roof with (8) 1-1/2" nails (four per side) through Reverse Gable Roof Panels into building Roof as shown.

7. Place one H-Clip centered on the unattached edge of the Left Large Roof Panel. Position the same size side of Small Roof Panel as rear of large panel into H-Clip. Align Small Roof Panel flush with Large Roof Panel at Ridge Board. Secure with (5) 1-1/2" nails, three into Roof Panels and two into Ridge Board, as shown.

Continue with opposite side in same fashion.

Finish Gable Ends and Trim using two coats of Exterior Grade Acrylic Latex Paint.

Note: Follow shingle manufacture recommendations for valley installation of shingles.

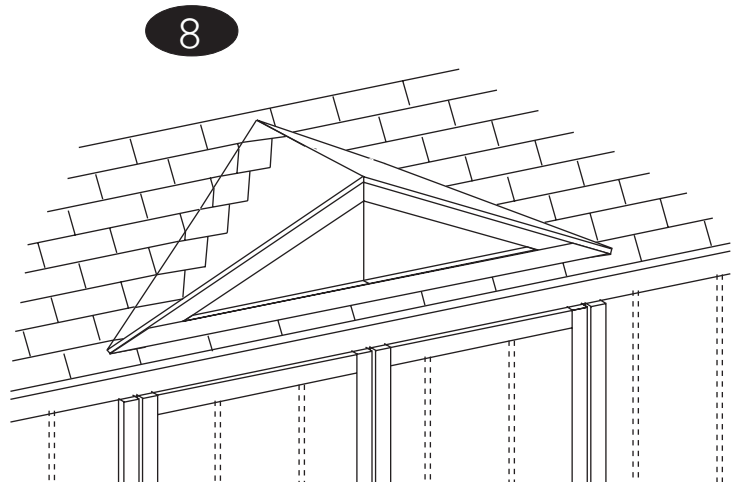
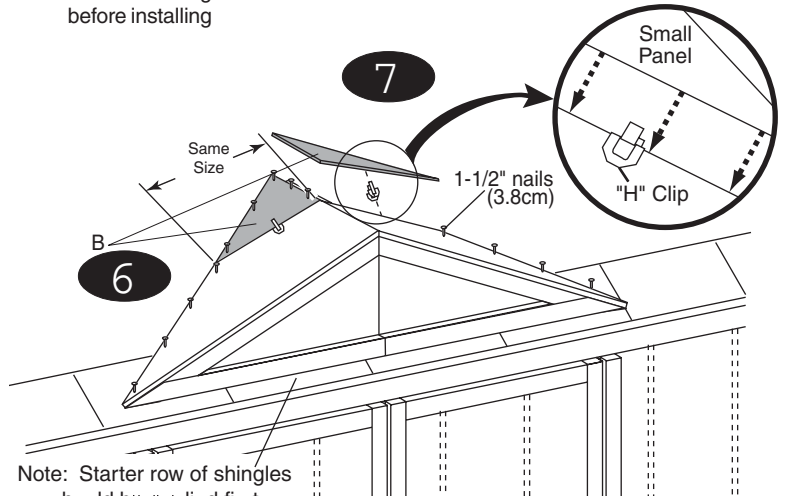
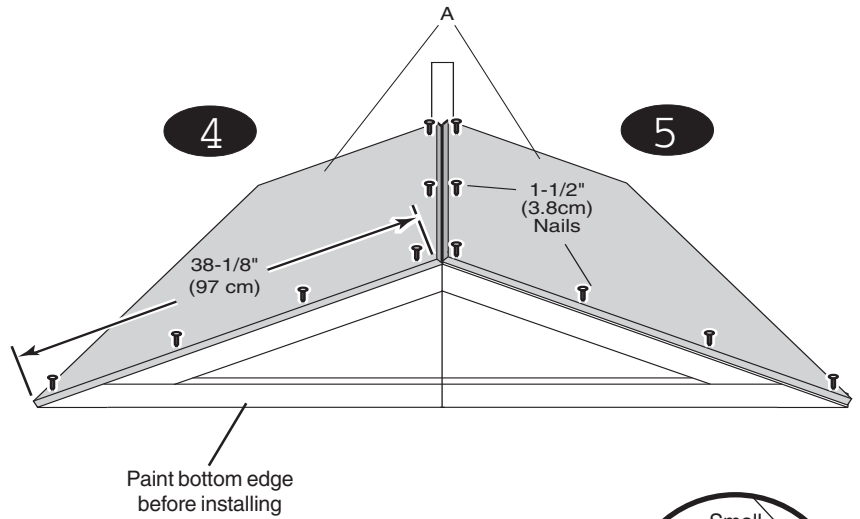

8-9. If building is not shingled, shingle building roof first. Follow all manufacturers instructions for shingling. Overlap reverse gable by 6" or more as shown in figure 8. If a shingle does not run up gable by 6" cut tab off and run a full shingle up gable. Once building roof is completed then shingle reverse gable as shown in figure 9. Run reverse gable shingles all the way to the valley where the roofs meet. Cut the shingles on the reverse gable back by 2".

9

